



EMPOWERING YOUR IDEAS

A photograph of a white ceramic bowl filled with brown sugar granules, sitting on a wooden surface. Several brown sugar cubes are scattered around the base of the bowl. The background is a light-colored wooden surface with a subtle grid pattern.

**SUGAR
TECHNOLOGIES**

02

STM TEAM POWER TRANSMISSION FOR SUGAR CANE PROCESSING

TRANSMISIÓN DE POTENCIA STM TEAM PARA EL PROCESO DE PRODUCCIÓN DEL AZÚCAR DE CAÑA

The growing importance of Sugar Cane processing, as a renewable source of nutrition (sugar) and of fuel (ethanol), gives to the power transmission a great role in the construction projects of new mills or in the refurbishing of old ones. STM team, a leader company in the field of power transmission, responds to the market demands, proposing its own solutions for the sugar mills application:

- > Hi-Torque gearboxes with a full range of reduction ratios, which guarantee a better speed control and synchronization.
- > Combined Planetary/Orthogonal gearboxes for a higher compactness and thermal power increasing.
- > Powerful and compact gearboxes, designed for specific application requirements.

Technological innovation "100% Made in Italy", quick assistance and local training of the staff have always been the keystones of all our winning products!

La creciente importancia del procesamiento de la caña azúcar, como fuente renovable de un recurso alimenticio (azúcar) o de un recurso combustible (etanol), hace la transmisión de potencia, una pieza fundamental en los proyectos de construcción de nuevos ingenios o de remodelación de viejos ingenios. STM team, empresa líder en el campo de la transmisión de potencia, responde a las exigencias del mercado, proponiendo sus propias soluciones para los ingenios azucareros:

- > Reductores de alto torque con gama completa de relaciones de reducción en grado de garantizar un mejor control de velocidad y sincronización.
- > Reductores combinados Planetario/Ortogonal para mayor compacteza e incremento del valor de potencia termica.
- > Reductores potentes y compactos, proyectados sobre exigencias aplicativas específicas.

Innovación tecnológica "100% Made in Italy", rápida asistencia y formación local del personal, son desde siempre, la piedra angular de nuestros productos vencedores!





Sugar Cane mills need to be always more performing in processing and increasing productivity. STM team is the ideal partner to achieve these key goals!

Los ingenios azucareros tienen que ser siempre más eficientes en el procesamiento y en el aumento de la productividad. STM team, es el socio ideal para lograr estos objetivos clave!

04

SUGAR PRODUCTION PROCESS PROCESO PRODUCCIÓN DE AZÚCAR

SUGAR MILLS TRAINS

(Small / Medium / Large Plants)

As Main or Pinion less drives, STM team gearboxes meet the demand of ratio, high torque and efficiency related to sugar cane milling process.

MOLIENDA CON MOLINOS (Ingenios Pequeños / Medios / Grandes)

Como accionamientos principales con acople de hilos o directos montados en flecha (Pinion less), los reductores STM team cubren perfectamente la demanda de relación de reducción, alto torque y eficiencia requeridos en los procesos de molienda de caña de azucar.

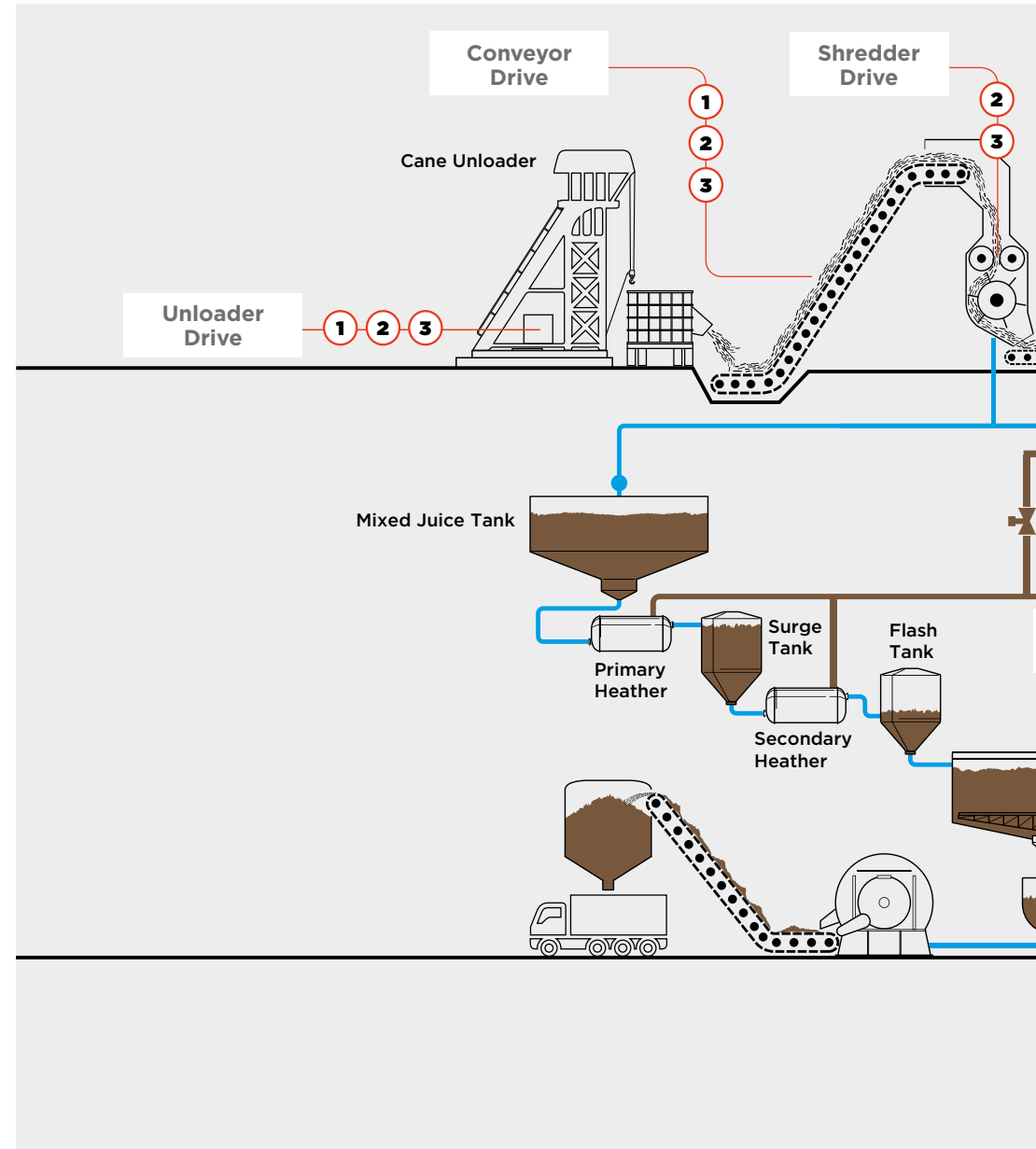

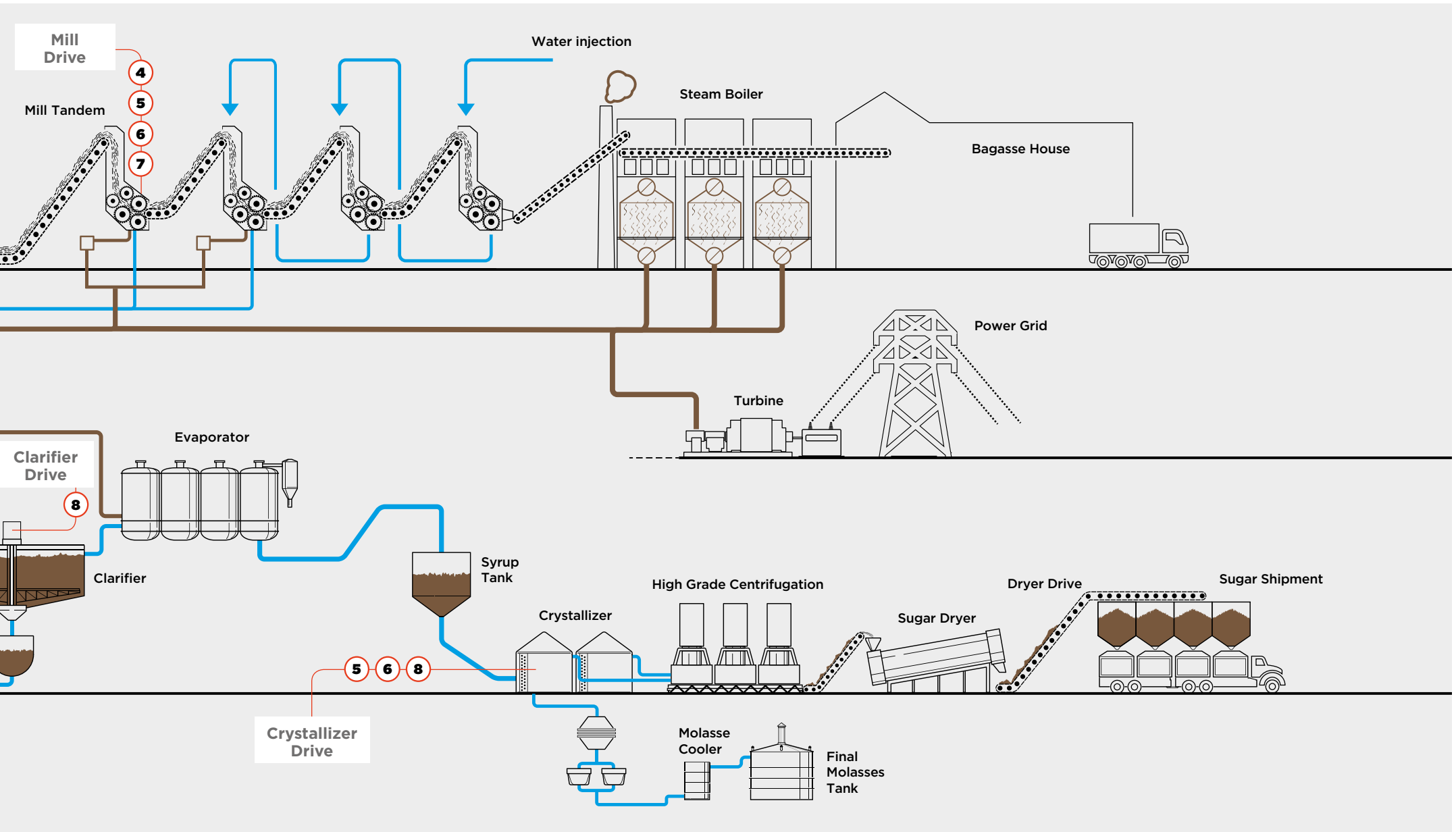

SUGAR PRODUCTION PROCESS

PROCESO PRODUCCIÓN DE AZÚCAR

SUGAR MILLS DIFFUSER

(Medium / Large Plants)

STM team planetary gearboxes are the most complete solution for diffuser drives, thanks to the full range of ratios, to the reliability of our gearboxes and considering the high torque and low speed conditions of this type of application.

MOLIENDA CON DIFUSOR

(Ingenios Medios / Grandes)

Los reductores epicicloidales STM team son la solución más completa para los accionamientos de difusores, debido a la amplia gama de relaciones de reducción disponibles y a la fiabilidad de nuestros reductores para las condiciones de baja velocidad y alto torque requeridos en este tipo de aplicación.

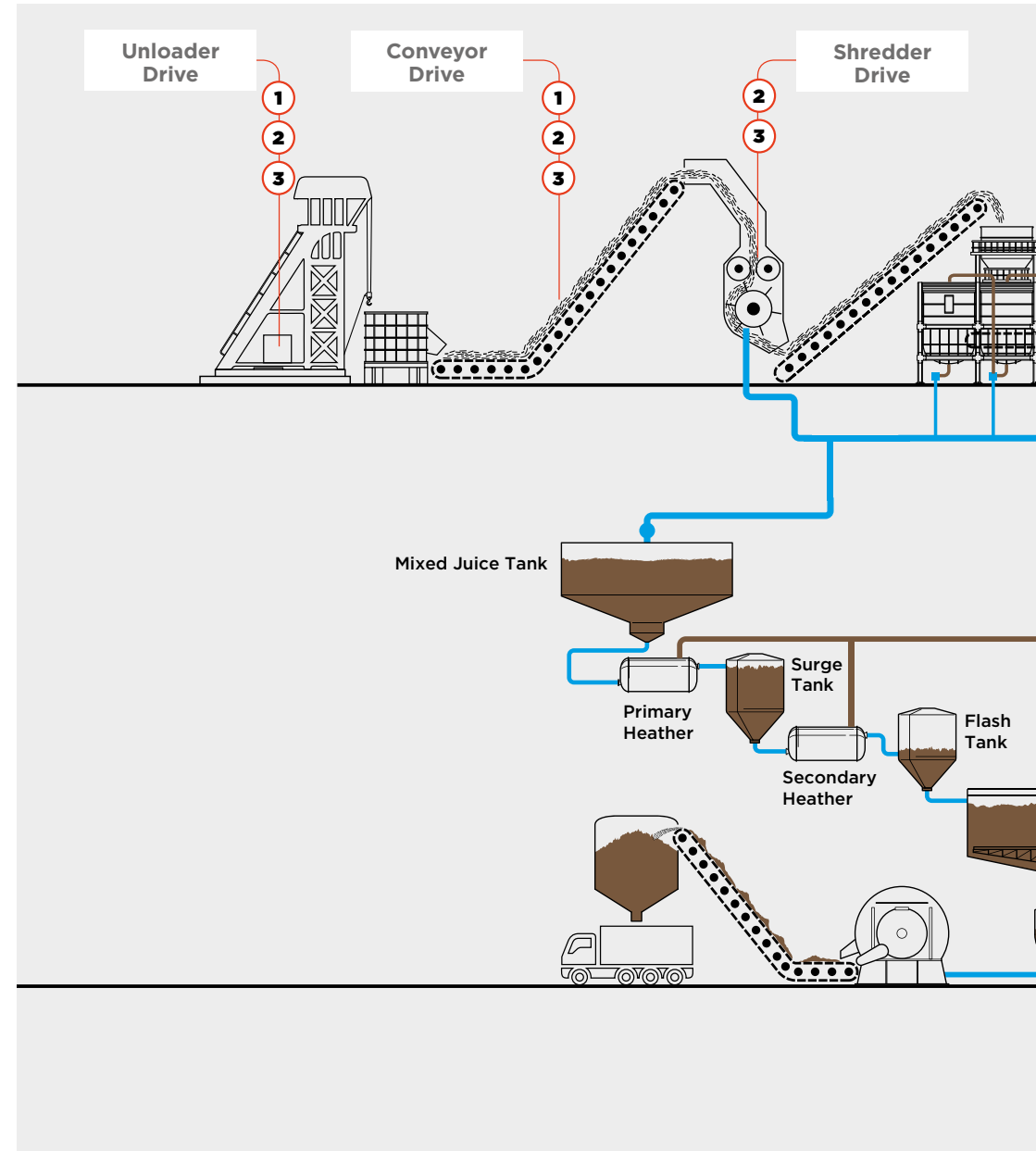

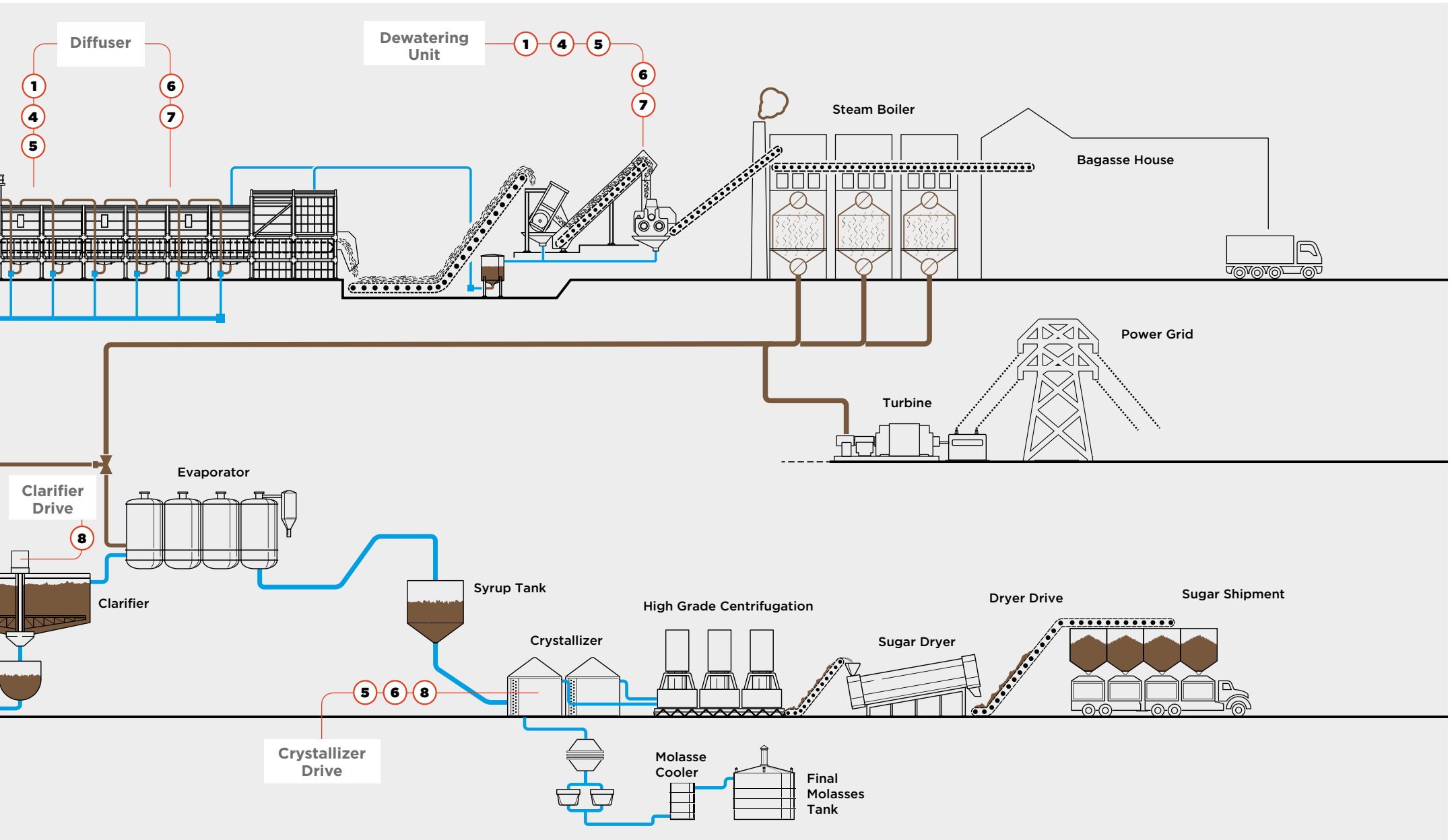

08

MAIN FEATURES OF THE MOST COMMON TRANSMISSION DRIVES USED IN SUGAR CANE MILLS

CARACTERÍSTICAS DE LOS ACCIONAMENTOS MÁS COMUNES USADOS EN LOS MOLINOS DE INGENIOS AZUCAREROS

COMPARISON BETWEEN CONVENTIONAL & PLANETARY SOLUTIONS

Component	Open gears	Conventional	Main drive	Pinion less
3-Phase Motor		98%	98%	98%
Gearbox	54%*	80%	92%	92%
Rope Coupling		98%	98%	-
Crown Pinion	90%	90%	90%	-
TOTAL EFFICIENCY	49%	69%	80%	90%

* Old trasmission system with steam turbine, turbogearbox, open gears and tail-bar, Teff=54%.

PINION LESS (Shaft mounted with torque arm)

SIN PIÑÓN (Montaje en flecha con brazo de reacción)



ADVANTAGES

- > Compact factory design.
- > No footprint at all and no need of foundations.
- > High efficiency: 90%.
- > Better extraction and reduced wear.
- > Low installation and maintenance costs.
- > Absence of external transmission through open gears for roller connection.
- > Variable speed control by means of single inverters.
- > Dramatically reduced plant downtimes.
- > Possibility to transform conventional mills into modern standards and take profit of all above advantages.

VENTAJAS

- > Diseño compacto de fábrica.
- > Base de apoyo despreciable y sin realización de cimientos.
- > Alta eficiencia: 90%.
- > Mejor extracción y menor desgaste.
- > Bajos costos de instalación y mantenimiento.
- > Ausencia de transmisiones externas y/o engranajes abiertas para accionamiento del molino.
- > Control variable de velocidad a través de inversores sencillos.
- > Notable reducción de paros de planta.
- > Permite la posibilidad de transformar ingenios convencionales hacia los modernos estandares y tomar el beneficio de todas las ventajas técnicas arriba indicadas.

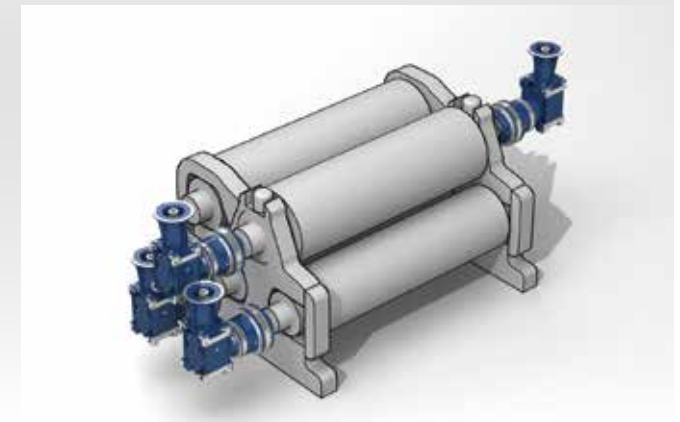

MAIN DRIVE

(Rope Coupling)

PRINCIPAL

(Acople Flexible o de Hilos)



ADVANTAGES

- > Reduced footprint.
- > Low installation and maintenance costs.
- > Medium/High efficiency: 80%.
- > Reduced plant downtimes.
- > Variable speed control by means of parallel inverter connections.

VENTAJAS

- > Base de apoyo reducida y con realización de cimientos.
- > Bajos costos de instalación y mantenimiento.
- > Media/Alta eficiencia: 80%.
- > Control variable de velocidad a través de conexión en paralelo de inversers.
- > Reducción moderada de paros de planta.

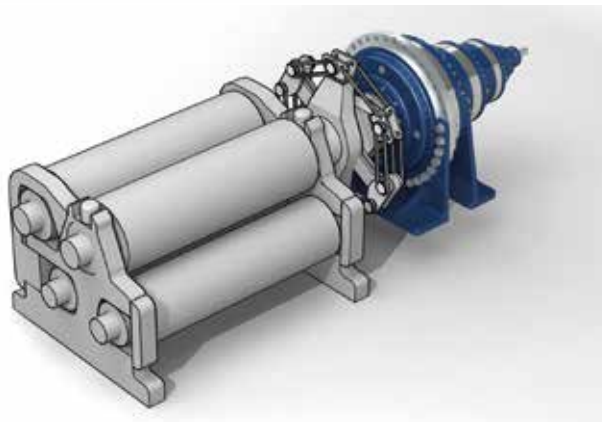

CONVENTIONAL CONVENCIONAL

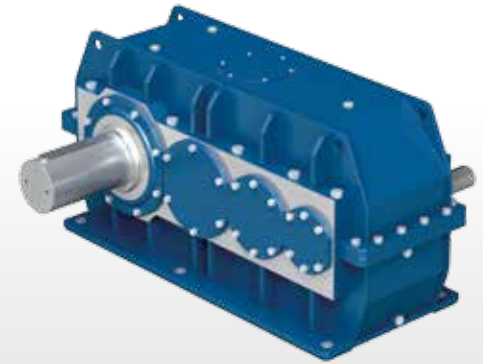

CHARACTERISTICS

- > Wide footprint.
- > Use of a big open gear transmission system.
- > Low efficiency: 69%.
- > High maintenance costs.

CARACTERISTICAS

- > Base de apoyo amplia y con realización de cimientos.
- > Uso de un grande sistema de transmisión de engranajes abiertos.
- > Baja eficiencia: 69%.
- > Altos costos de mantenimiento.

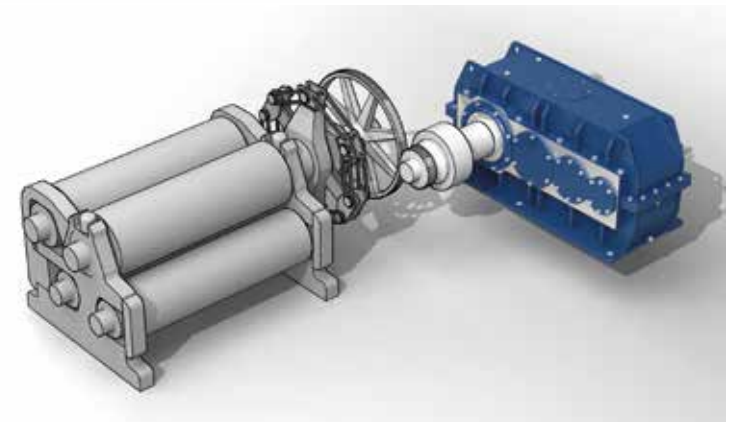

10

THE MOST IMPORTANT GEARBOX APPLICATIONS FOR SUGAR MILLS

LAS APLICACIONES MÁS IMPORTANTES DE LOS REDUCTORES EN INGENIOS AZUCAREROS

Sugar Cane processing is based on several machines, whose gearbox applications play a key role. Among these, the most important are the conveyors, the diffuser plants and the crystallizers. Their efficiency, reliability and low maintenance time and costs assure the best mills' performances.

El procesamiento de la caña de azúcar esta basado en varias máquinas, en las cuales el reductor juega un papel clave. Entre estas, las más importantes son los transportadores, los difusores y los cristalizadores. Por lo tanto, su eficiencia, su fiabilidad, y sus bajos tiempos / costos de mantenimiento aseguran mejores eficiencias de molienda en los ingenios azucareros.

CONVEYORS TRANSPORTADORES

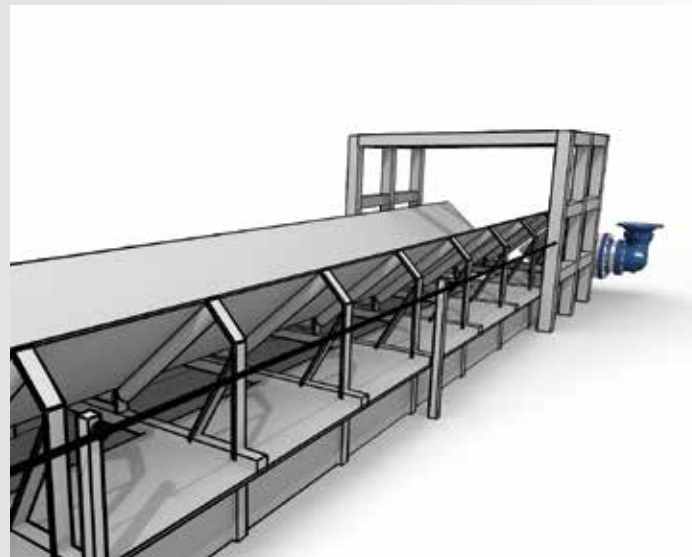

Model	Size	Nominal [Nm]	Max [Nm]
EX/EXB	1503	20.000	41.000
EX/EXB	1803	25.000	41.000
EX/EXB	2003	30.000	41.000
EX/EXB	2503	35.000	63.000
EX/EXB	2803	35.000	63.000
EX/EXB	3003	40.000	71.000
EX/EXB	3503	45.000	90.000
EX/EXB	3603	45.000	90.000
EX/EXB	4203	55.000	95.000

DIFFUSER PLANT DIFUSOR

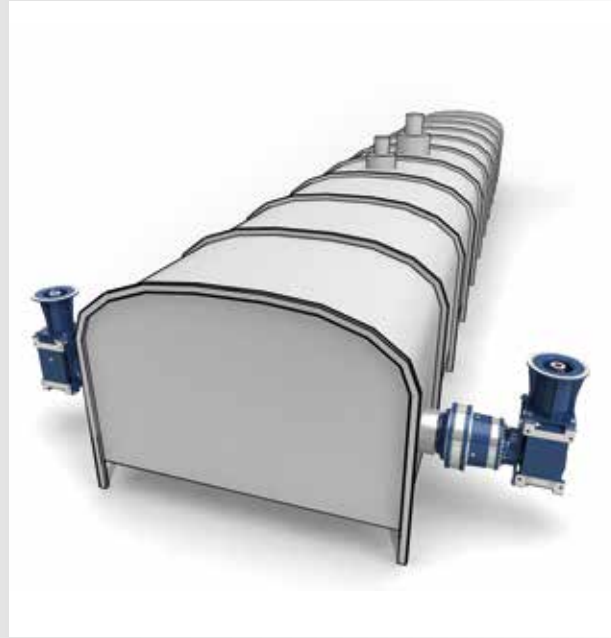

Model	Size	Nominal [Nm]	Max [Nm]
EXR	55002/822	580.000	1.100.000
EXR	68002/824	660.000	1.300.000
EXR	75002/824	820.000	1.500.000
EXR	80002/824	870.000	1.500.000
EXR	85002/824	920.000	1.800.000
EXR	100002/824	1.060.000	2.100.000
EXR	120002/824	1.370.000	2.500.000
EXR	130003/820	1.340.000	2.800.000
EXR	150003/822	1.550.000	3.200.000
EXR	170003/822	2.040.000	3.800.000
EXR	200003/822	2.120.000	4.500.000
EXR	235003/824	2.530.000	5.100.000
EXR	250003/824	2.700.000	6.200.000
EXR	300003/824	3.050.000	6.200.000

CRYSTALLIZER CRISTALIZADOR

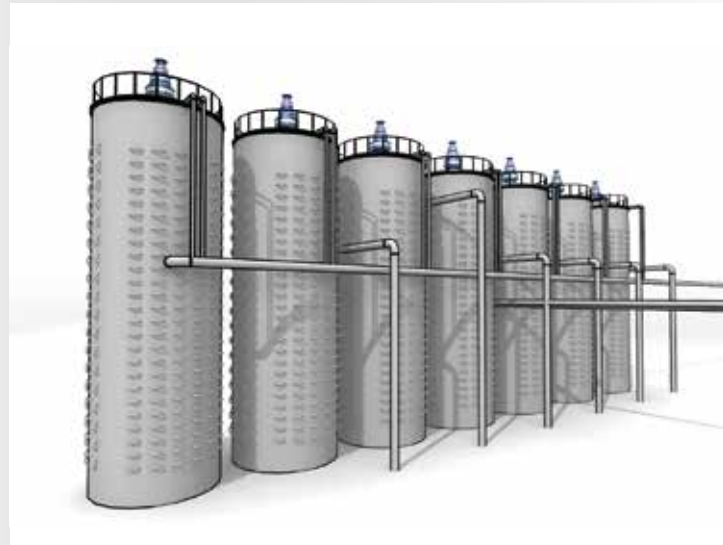

Model	Size	Nominal [Nm]	Max [Nm]
EX/EXB	2505	35.000	63.000
EX/EXB	2805	35.000	63.000
EX/EXB	3005	40.000	71.000
EX/EXB	3505	45.000	90.000
EX/EXB	3605	45.000	90.000
EX/EXB	4205	55.000	95.000
EX/EXB	6005	75.000	145.000
EX/EXB	6505	80.000	145.000
EX/EXB	8005	95.000	190.000
EX/EXB	8505	105.000	190.000
EX/EXB	10005	135.000	235.000
EX/EXB	12005	150.000	295.000

SUGAR MILL GEARBOX FOR MAIN DRIVES REDUCTOR PLANETARIO PARA ACCIONAMIENTOS PRINCIPALES

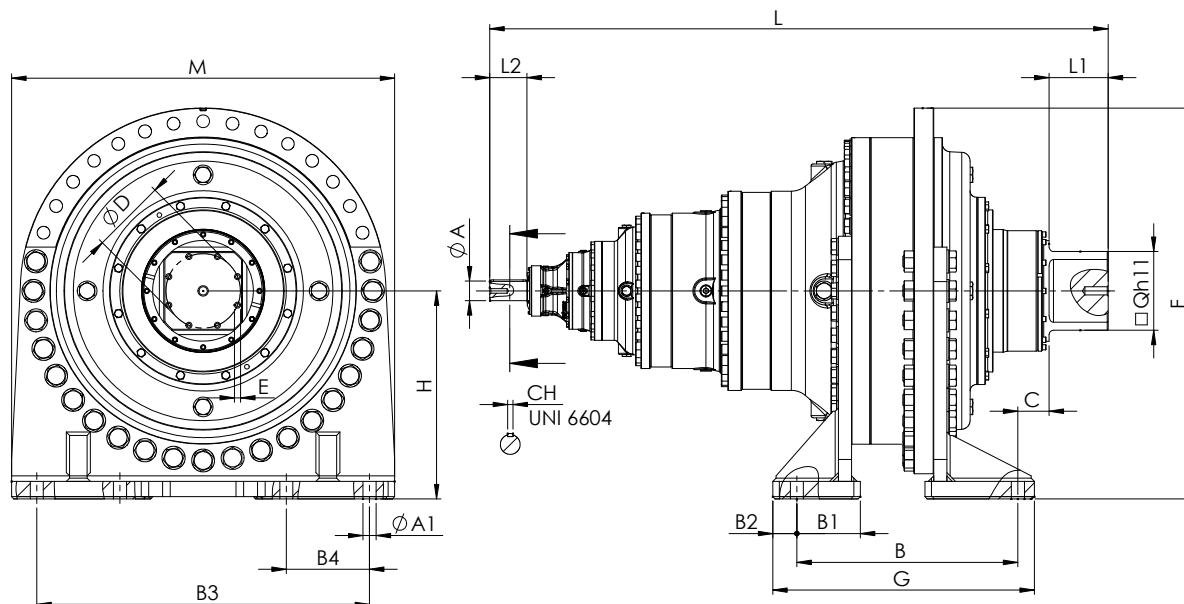

Model	Nominal [Nm]	Max [Nm]
EX 8000	870.000	1.500.000
EX 8500	920.000	1.800.000
EX 10000	1.060.000	2.100.000
EX 12000	1.310.000	2.500.000
EX 13000	1.380.000	2.800.000
EX 15000	1.550.000	3.200.000
EX 17000	2.040.000	3.800.000
EX 20000	2.120.000	4.500.000
EX 23500	2.530.000	5.100.000
EX 25000	2.700.000	5.300.000
EX 30000	3.050.000	6.200.000

Model	ØA	ØA1	B	B1	B2	B3	B4	C	ØD	E	F	G	H	L	L1	L2	M	□Q
EX 8000	150	52 (8)	645	197	80	1100	200	242,5	280	M20 (8)	1145	1250	640	2577,5	250	230	1250	320
EX 8500	150	60 (8)	865	295	105	1450	380	180	280	M20 (8)	1460	1660	850	2665	250	230	1660	320
EX 10000	150	60 (8)	865	295	105	1450	380	214,5	340	M20 (8)	1460	1660	850	2772	280	230	1660	360
EX 12000	150	60 (8)	865	295	105	1450	380	214,5	340	M20 (8)	1460	1660	850	2803,5	280	230	1660	360
EX 13000	150	60 (8)	885	290	110	1520	380	287,5	360	M20 (8)	1650	1750	950	2941,5	280	230	1750	360
EX 15000	180	60 (8)	885	290	110	1520	380	287,5	360	M20 (8)	1650	1750	950	3062,5	320	240	1750	400
EX 17000	180	85 (8)	885	290	110	1520	380	287,5	360	M20 (8)	1650	1750	950	3062,5	320	240	1750	400
EX 20000	180	85 (8)	1000	330	100	1770	380	341	420	M20 (12)	1845	2000	1050	3478,5	350	240	2000	450
EX 23500	180	85 (8)	1000	330	100	1770	380	341	420	M20 (12)	1845	2000	1050	3354	350	240	2000	450
EX 25000	180	85 (8)	1000	365	105	2000	400	449,5	450	M27 (12)	2025	2000	1150	3718,5	400	240	2000	500
EX 30000	180	85 (8)	1000	365	105	2000	400	449,5	450	M27 (12)	2025	2000	1150	3757,5	400	240	2000	500

Inspection cover
Tapa de inspección

Optimized bearings life
Vida rodamientos optimizada

Double oil seals and protection cover
Doble reten y tapa de protección

Forced lubrication & cooling system
Lubricación forzada y sistema de enfriamiento

3, 4 & 5 satellites with total ratio in only 3 stages
3, 4 & 5 satélites con gama relaciones completas en solo 3 trenes

Removable square shaft to reduce the maintenance cost
Eje cuadrado de salida removible para reducir costos de mantenimiento

FEM analysis to minimize the vibrations
Análisis FEM para minimizar vibraciones

Double oil seals and protection cover
Doble reten y tapa de protección

Symmetrical fixing feet to uniform mounting load
Base de fijación simétrica para uniformizar carga de montaje

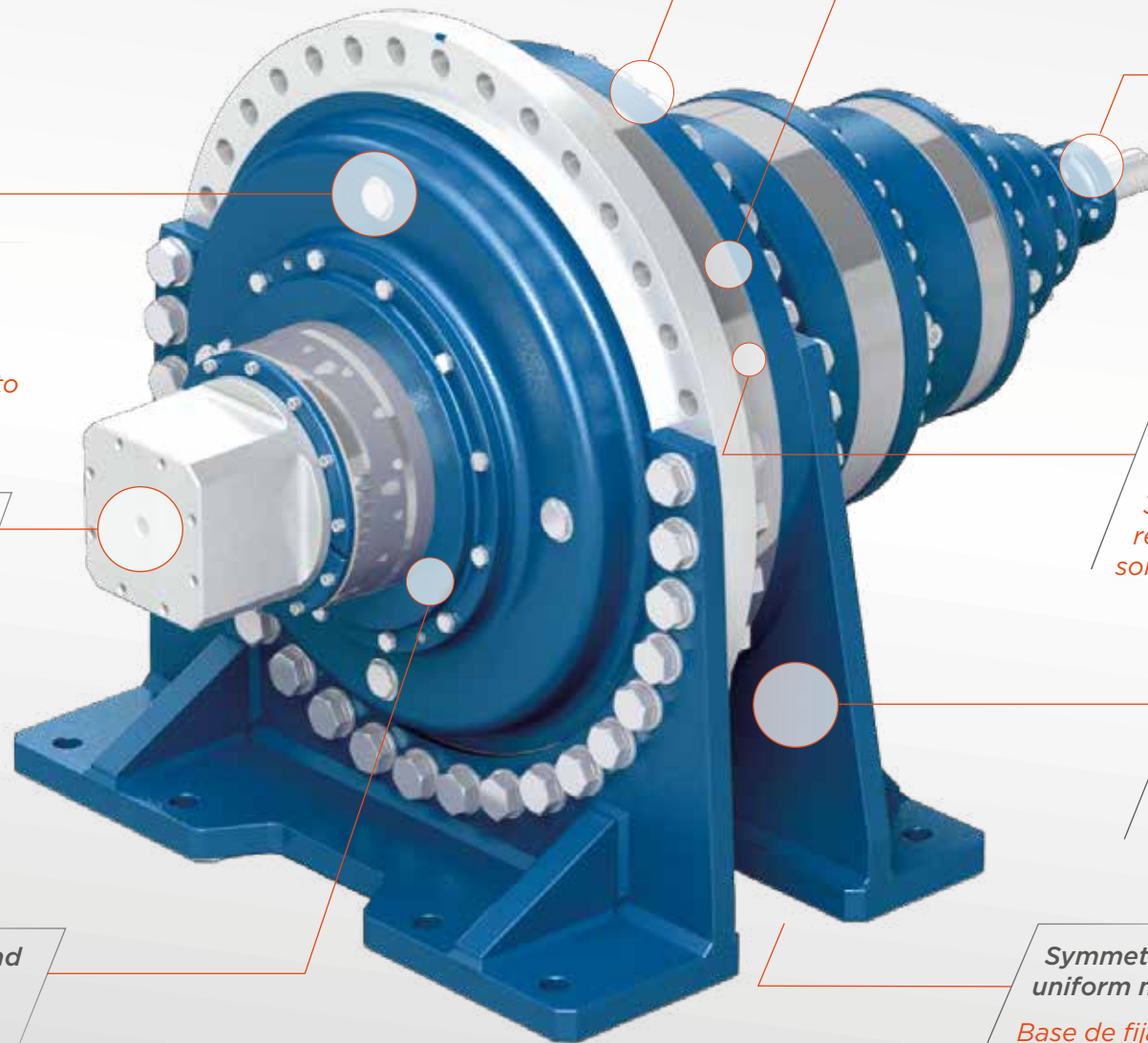

RED BUTTON SERVICE

RED BUTTON fast delivery service was born to satisfy the urgent need of our customers to be supplied with our gearboxes, geared motors and speed variators. If you have to face an unexpected problem, if your production suddenly stops, if your warehouse inventory is not enough to fulfill your demands, STM is there to help you with its RED BUTTON service! It will take us only from 24 hours (for products in stock) to 72 hours (for big dimension gearboxes, whose spare parts are already in stock) to supply you with the products you need. **STM, faster and faster beside you!**

La oferta mundial de servicios de STM se enriqueció con el sistema rápido de entrega RED BUTTON, cuyo objetivo es satisfacer a nuestros clientes que están en necesidad urgente de recibir nuestros reductores, motorreductores y variadores mecánicos. En caso de accidente inesperado y la producción se pare de repente o si surge el problema que las existencias de almacén son insuficientes en comparación con las necesidades, el nuestro servicio RED BUTTON está listo para responder con rapidez: a partir de las 24 horas (para productos que ya están en stock) hasta 72 horas (para productos grandes, cuyos componentes estén disponibles en stock) y de este modo enviar los reductores de velocidad STM que a Ustedes les sirvan!!! **¡STM, siempre más rápidamente al Vuestro lado!**



CONFIGURATOR

A guided navigation will follow in the configuration of your gearbox to get quickly size for your project. The world of STM gearboxes will be available for you in all its forms!

A través de la navegación guiada es posible definir el reductor para obtener en modo rápido el dimensional de vuestro proyecto. ¡Cada forma dentro del mundo de reductores STM estará a vuestra disposición!



INTERACTIVE

STM and GSM provide the opportunity to track the progress of orders “on line”, with the purpose of getting a great level of interactivity and of improving the efficiency of their service.

Con el objetivo de volver el servicio interactivo y de alta calidad para nuestros clientes, STM y GSM ofrecen la oportunidad de seguir “on line” el progreso de los pedidos.

AFTER SALES

STM and GSM guarantee a very detailed and efficient pre and after sales assistance through a qualified network of salesmen and technicians, who are ready to solve any problem in the shortest time and in the best way.

STM y GSM garantizan una asistencia pre y post venta presente y puntual, asegurada gracias a una red cualificada de representantes de ventas y técnicos listos para solucionar cualquier problema, de forma rápida y eficaz.

OUR CERTIFICATIONS

STM and GSM are ISO 9001, ATEX, GOST, CCC certified. GSM is also a CTI member.

STM y GSM tienen las siguientes certificaciones: ISO 9001, ATEX, GOST, CCC. GSM es también miembro CTI.



ITALY

STM LOMBARDIA

Via Velleia, 1
20052 Monza (Mi)
T: +39/039/83.79.41
F: +39/039/83.79.490
sef@sefmotoriduttori.com

STM PIEMONTE

Strada del Cascinotto, 139/43B
10156 TORINO
T: +39/011/22.38.463
F: +39/011/22.38.463
info@labet.it

STM VENETO

Via Manfredini, 54
45100 Loc. Granzette ROVIGO
T: +39/0425/48.61.58
F: +39/0425/93 20 68
stmveneto@stmspa.com

STM SERVICE

Via Enrico Fermi, 35
00044 Frascati (RM)
T: +39/06/97.60.85.44
F: +39/06/97.60.85.45
info@tecnodrivresrl.it

STM SUD

Via Ottaviano, 298/300
80040 San Gennaro Vesuviano (Na)
T: +39/081/52.86.802
F: +39/081/52.86.803
info@stmsud.it

EUROPE

STM DEUTSCHLAND

Gewerbepark Markfeld 7a
83043 BAD AIBLING
T: +49/8061/937680
F: +49/8061/9376829
stmdeutschland@stmspa.com

STM POWER TRANSMISSION UK

UNIT 1 OASIS BUSINESS PARK
ROAD ONE, WINSFORD Industrial
Est - CW7 3RY - WINSFORD
T: +44/1606/557200
F: +44/1606/557396
info@stmuk.co.uk

STM SCHWEIZ

Bösch 27
6331 Hünenberg - SVIZZERA
T: 0041 41 7832970
F: 0041 41 7832971
info@eurodrives.ch

STM RUSSIA

Bolshaya Pochtovaya st. 30
105082 Mosca
T: +74/957836809
F: +74/952672073
ars@ttaars.ru

STM SWEDEN

Stathogavagen, 48 - 60223 Norrköping
T: +46/11158340
F: +46/11158349
info@stmSweden.se

STM IBERIA

Contrada Nacional 121, km 39,400
31390 Olite Navarra
T: +34/948712017
F: +34/948712153
martinena@martinenas.es

STM AANDRIJFTECHNIEK NL

Jan Vrijmanstraat, 12
1087 MC, Amsterdam -
The Netherlands
T: + 31/20 3586361
F: +31/20 3419831
info@stmaandrijftechniek.nl

STM UKRAINE

Belaia Tzerkov Yaroslava Mudrogo,
ST66/13
09107 Region of Kiev
T: +38/04463519369
F: +38/0446391037
stm@stm.com.ua

STM TURKIYE

10026 - IZMIR
Str. No: 54 AOSB CIGLI
T: 0090.232.328 36 39
F: 0090.232.328 36 40
info@novaguc.com

STM FINLAND

Luoteisrinne, 5 - 02270 Espoo
T: +35/8440674519
F: +35/8104256805
info@stmfinland.fi

STM TRANSMISSIONS FR

T: +33 06 59 28 59 31
jl.bonnet-ligeon@stmspa.com

WORLD

STM YOUNG POWERTECH INC

3060 PLAZA DR. #107
19061 - GARNET VALLEY - PA
T: 0016105580760
F: 0016505580762
Info@youngpowertech.com

STM SOUTH AFRICA

47 Paul Smit street
BOKSBURG NORTH JOHANNESBURG
T: +27/011 892 4874
F: +27/011 892 2596
stmtrans@netactive.co.za

STM KOREA

#104-216, 41, Yutongdanji 1-ro,
Gangseo-gu, Busan,
618-899 Rep. of KOREA
T: +82-10-8536-6469,
+82-70-8730-1238
F: +82-51-955-2250
stmapkorea@gmail.com

STM MEXICO

T: +52 33 36150087
info@stmMexico.com.mx

STM INDIA

T: +91 99 42559285
k.saravanan@stmspa.com

STM AUSTRALIA

13/97 Bayfield Road East
Bayswater - VIC 3153
T: +61/397617355
F: +61/397617222
pbeveridge@hmagroup.com.au

STM ARGENTINA

Langeri, 3525 (Santos Lugares)
1676 Buenos Aires
T: +54/11/41.15.63.85
F: +54/11/47.57.05.12
comercial@stmteam.com.ar

STM AP (ASIA PACIFIC)

6 Penjuru Place #01-32 Penjuru Tech
Hub, Singapore 608781
T: 65-6266 2022
F: 65-6266 5955
stm@stmap.com

STM DO BRASIL

Rua Padre Raposo,
1293 Mooca (SP)
T: +55/11/2605.1144
F: +55/11/2601.1559
stm Dobrasil@stm Dobrasil.com

STM BEIJING

Rm306, Blk A, Jingjiang Building,
#35, Bagou Nan Rd, Haidian Dist.
Beijing 100089, China
T: 0086 10 8256 5319
F: 0086 10 8255 1142
stm@stmchina.cn





STM S.p.A.
Headquarters

Via del Maccabreccia, 39
40012 Lippo di Calderara di Reno (BO)
Tel. +39 051 37 65 711
Fax +39 051 64 66 178
www.stmspa.com - info@stmspa.com



GSM S.p.A.
Via Malavolti, 48

41122 Modena - Italy
Tel. +39 051 37 65 711
Fax +39 051 64 66 178
www.stmspa.com - info@stmspa.com

